

1999 Acura Integra LS

1999-2000 ENGINES 1.8L VTEC 4-Cylinder

1999-2000 ENGINES

1.8L VTEC 4-Cylinder

ENGINE IDENTIFICATION

NOTE: For repair procedures not covered in this article, see **ENGINE OVERHAUL PROCEDURES** article in **GENERAL INFORMATION**.

Engine identification code is stamped on right rear of cylinder block as viewed from flywheel, below cylinder head mating surface. First 5 numbers of code indicate engine type. Last 7 numbers of code indicate engine serial number.

ENGINE IDENTIFICATION CODE

Application	Code
1.8L	B18C1
1.8L	B18C5

ADJUSTMENTS

VALVE CLEARANCE

CAUTION: Only rotate engine in direction of normal rotation (counterclockwise as viewed from front of engine). Clockwise rotation may cause timing belt to jump camshaft pulley teeth.

NOTE: Valves should be adjusted cold, when cylinder head temperature is less than 100°F (38°C). Adjustment procedures are the same for both intake and exhaust valves.

1. Remove valve cover. Rotate crankshaft counterclockwise so No. 1 piston is at TDC of compression stroke. Ensure UP marks on camshaft sprockets are at top pointing up, and TDC grooves on pulleys are aligned with TDC mark on back cover. See **Fig. 1**.
2. Adjust valve clearance on both valves for No. 1 cylinder. Loosen lock nuts. Rotate adjuster screw until clearance is as specified. Tighten lock nut to 15 ft. lbs. (20 N.m). Recheck adjustment. See **VALVE CLEARANCE SPECIFICATIONS** table.
3. Rotate crankshaft 180 degrees counterclockwise (camshaft sprockets turn 90 degrees) until No. 3 piston is at TDC of compression stroke. UP marks on camshaft sprockets should point to exhaust side of cylinder head. Adjust valve clearance on both valves for No. 3 cylinder.
4. Rotate crankshaft 180 degrees counterclockwise until No. 4 piston is at TDC of compression stroke. Ensure UP marks on camshaft sprockets are pointing down. Adjust valve clearance on both valves for No. 4 cylinder.
5. Rotate crankshaft 180 degrees counterclockwise until No. 2 piston is at TDC of compression stroke. Ensure UP marks on camshaft sprockets are pointing to intake side of cylinder head. Adjust valve clearance on both valves for No. 2 cylinder. Install NEW valve cover gasket. Install valve cover.

VALVE CLEARANCE SPECIFICATIONS

www.SoftCar.ru		
18 февраля 2007 г. 19:12:22	Page 1	© 2005 Mitchell Repair Information Company, LLC.

1999 Acura Integra LS

1999-2000 ENGINES 1.8L VTEC 4-Cylinder

Application	In. (mm)
Exhaust	0.007-0.008 (0.18-0.20)
Intake	0.006-0.007 (0.15-0.18)

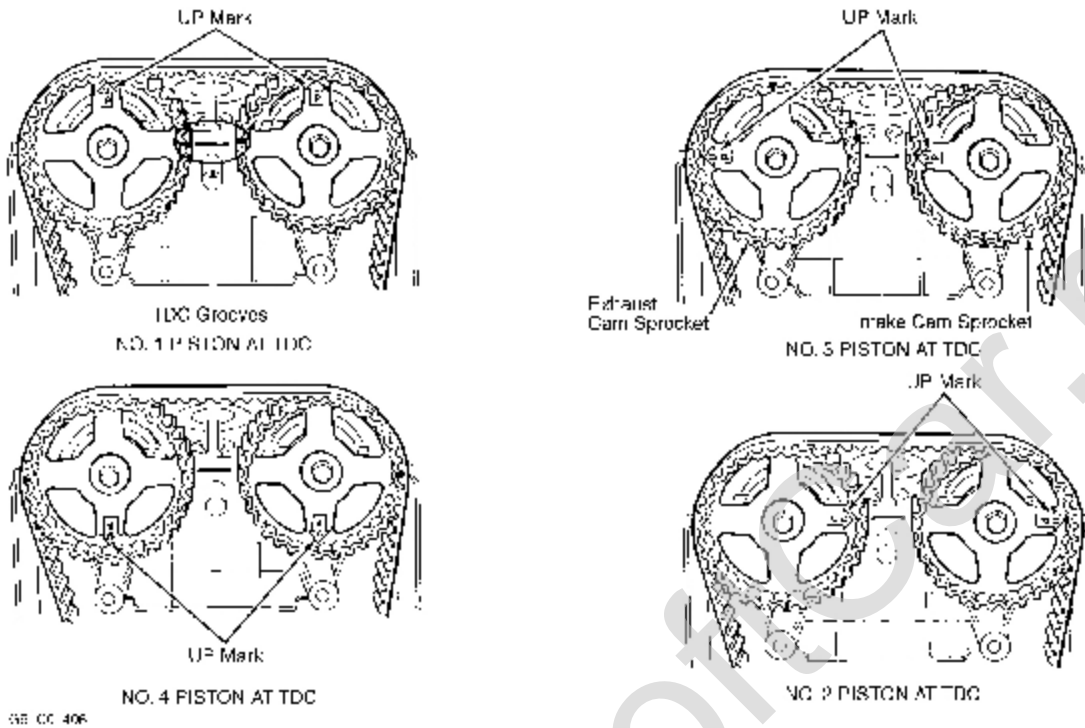

Fig. 1: Positioning Camshafts For Valve Clearance Adjustment
 Courtesy of AMERICAN HONDA MOTOR CO., INC.

TIMING BELT TENSION

CAUTION: Adjust timing belt with engine cold. DO NOT rotate crankshaft with timing belt tensioner adjuster bolt loose.

Remove valve cover. Rotate crankshaft 5-6 revolutions counterclockwise to create tension on timing belt. Rotate crankshaft counterclockwise until No. 1 piston is at TDC. Loosen tension adjuster bolt one half turn (180 degrees). See **Fig. 2**. Rotate crankshaft counterclockwise enough to create tension on timing belt. Tighten tension adjuster bolt to specification. See **TORQUE SPECIFICATIONS**. Install valve cover with NEW gaskets.

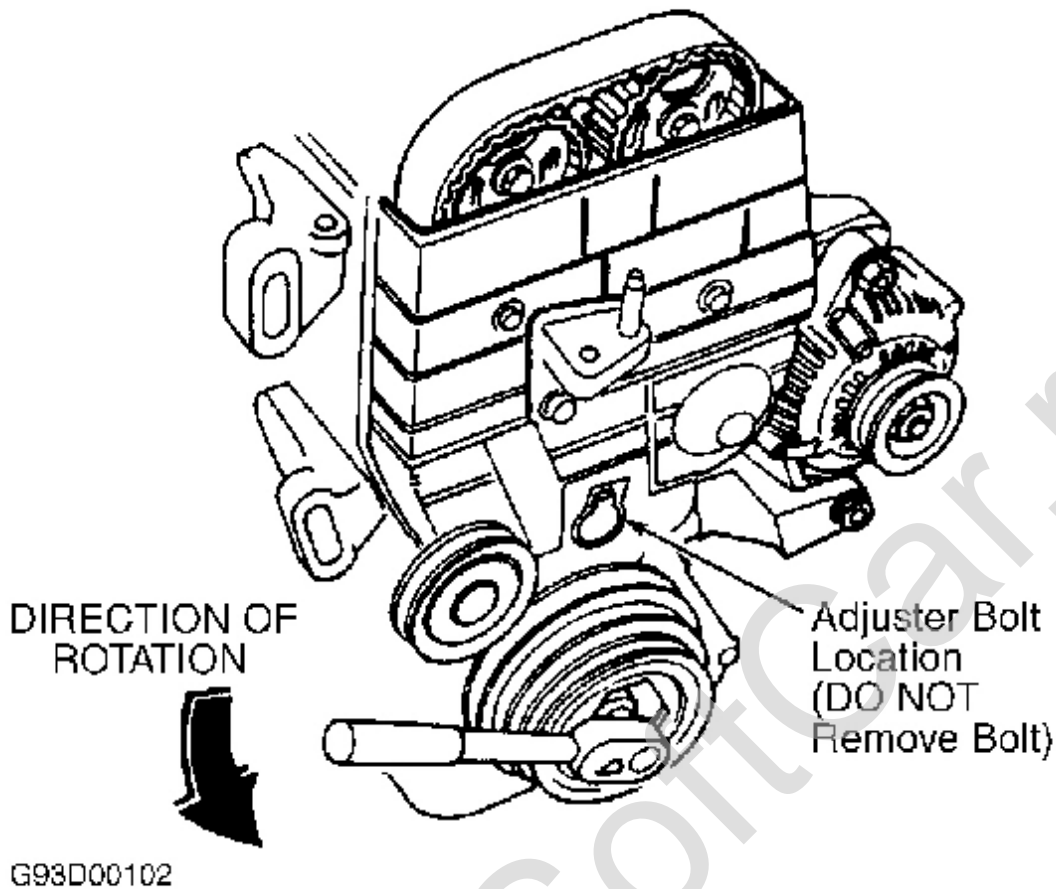

Fig. 2: Locating Timing Belt Adjuster Bolt
Courtesy of AMERICAN HONDA MOTOR CO., INC.

TROUBLE SHOOTING

To trouble shoot mechanical engine components, see appropriate table in TROUBLE SHOOTING article in GENERAL INFORMATION.

REMOVAL & INSTALLATION

- NOTE:** For repair procedures not covered in this article, see **ENGINE OVERHAUL PROCEDURES** article in GENERAL INFORMATION.
- NOTE:** For installation reference, label all electrical connectors, vacuum hoses, and fuel lines before removal. Also, place mating marks on engine hood and other major assemblies before removal.

CAUTION: When battery is disconnected, vehicle computer and memory systems may lose memory data. Driveability problems may exist until computer

systems have completed a relearn cycle. Obtain radio anti-theft codes, if necessary, before disconnecting battery.

CAUTION: Fuel system is under pressure. Release pressure before servicing fuel system components. See **FUEL PRESSURE RELEASE** .

FUEL PRESSURE RELEASE

Disconnect negative battery cable. Remove fuel tank filler cap. Place a shop towel on top of fuel filter. Release fuel injection system pressure by slowly loosening fuel filter banjo bolt. See **Fig. 3** .

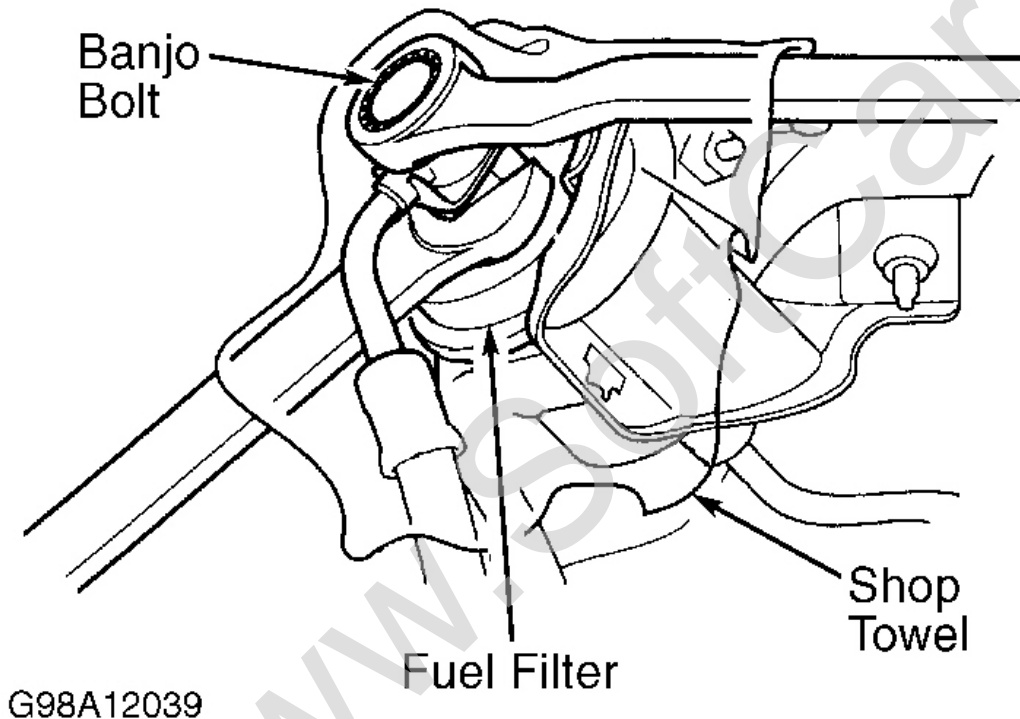

Fig. 3: Releasing Fuel System Pressure
Courtesy of AMERICAN HONDA MOTOR CO., INC.

BLEEDING COOLING SYSTEM

See BLEEDING COOLING SYSTEM in SPECIFICATIONS article in ENGINE COOLING.

ENGINE

WARNING: Make sure jacks and safety stands are placed properly, and hoist brackets are attached to correct positions on engine. Make sure car will not roll off stands and fall while working under it.

1999 Acura Integra LS

1999-2000 ENGINES 1.8L VTEC 4-Cylinder

Removal

1. Remove hood. Remove strut brace. Disconnect battery cables. Disconnect battery cables from underhood fuse/relay box and ABS fuse/relay box. Remove intake air duct, air cleaner housing assembly and bracket. Remove EVAP canister hose.
2. Disconnect engine wire harness connectors on right side of engine compartment. Release fuel pressure. See **FUEL PRESSURE RELEASE** . Remove fuel feed and fuel return lines. Remove brake booster vacuum hose. Remove throttle cable by loosening lock nut and removing cable end from accelerator linkage.
3. Disconnect engine wire harness connectors on left side of engine compartment. Remove harness clamps. Remove cruise control actuator. Remove engine ground cable. Remove power steering pump belt and mounting bolts. Remove power steering pump, with hoses attached, and wire aside.
4. Loosen idler pulley bolt and adjusting bolt. Remove air conditioning compressor belt. On manual transmission models, remove clutch slave cylinder, leaving hydraulic line attached. On all models, remove transmission ground cable.
5. Remove radiator cap. Raise and support vehicle. Remove front wheels and splash shield. Drain engine and transmission oil. Reinstall engine and transmission drain plugs using NEW washers. Drain cooling system. Remove upper and lower radiator hoses and heater hoses. On automatic transmission models, remove ATF cooler hoses.
6. On all models, remove radiator assembly. Remove A/C compressor, with hoses attached, and wire aside. Disconnect oxygen sensor and remove exhaust pipe "A". See **Fig. 4** . On manual transmission models, remove shift rod and extension rod. On automatic transmission models, remove shift cable. On all models, remove damper fork and disconnect suspension lower arm ball joints. Remove axle shafts.
7. Attach chain hoist to engine. Raise hoist to take slack from chain. Remove left and right front engine mounts and brackets. Remove rear and side engine mount brackets. Remove transmission mount. Ensure all hoses and electrical connectors have been removed. Slowly raise engine, once again ensure all hoses and electrical connectors have been disconnected. Raise engine and remove from vehicle.

Installation

1. To install, reverse removal procedure. To prevent excessive engine vibration and premature engine mount wear, tighten engine/transaxle mounts in sequence specified in next step. See **Fig. 5** .
2. Install transmission mount and tighten bolts/nuts to transmission, but leave mount-to-frame bolt loose. Install engine side mount and tighten bolts/nuts to engine, but leave mount-to-frame bolt loose. Tighten mount to frame bolts on transmission mount and side engine mount. Install rear mount bracket. Tighten rear mount bracket bolts to engine first, then to frame. Install right front mounting bracket and tighten bolts to engine first, then to frame. Install left front mounting bracket and tighten bolts to engine first, then to frame.
3. When installing axle shafts, use NEW spring clips. Insert axle shafts until spring clips click into groove of differential side gear. Ensure harness connectors and hoses are connected properly. Ensure control cables are not bent or pinched and are adjusted properly. Tighten remaining bolts/nuts to specification. See **TORQUE SPECIFICATIONS** . On manual transmission models, adjust clutch pedal free play and verify transaxle shifts smoothly.
4. On all models, adjust drive belt tension. Fill or top off all fluids. Fill and bleed air from cooling system. See **BLEEDING COOLING SYSTEM** . Start engine and check for leaks.

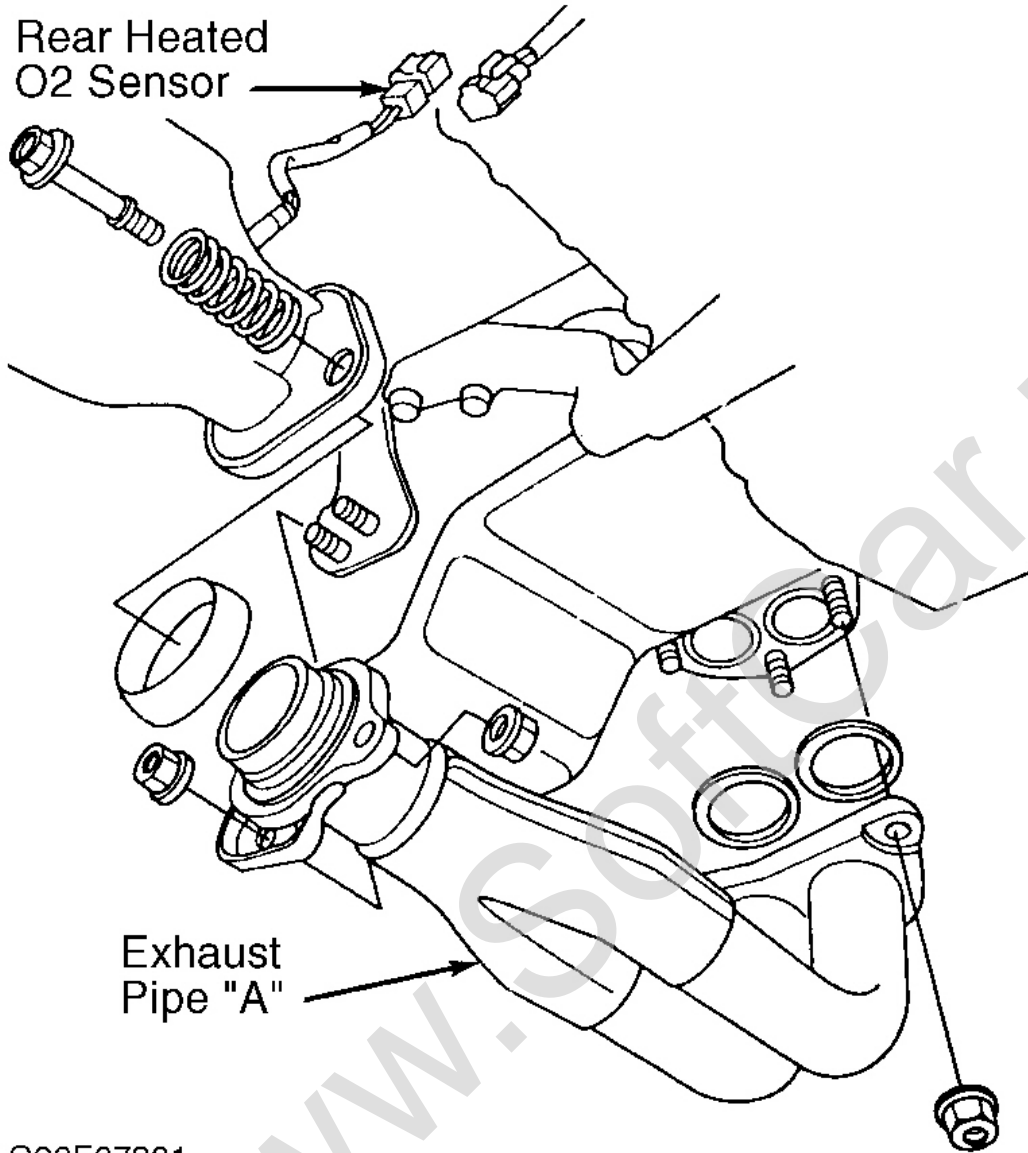

Fig. 4: Locating Exhaust System Components
Courtesy of AMERICAN HONDA MOTOR CO., INC.

1999 Acura Integra LS

1999-2000 ENGINES 1.8L VTEC 4-Cylinder

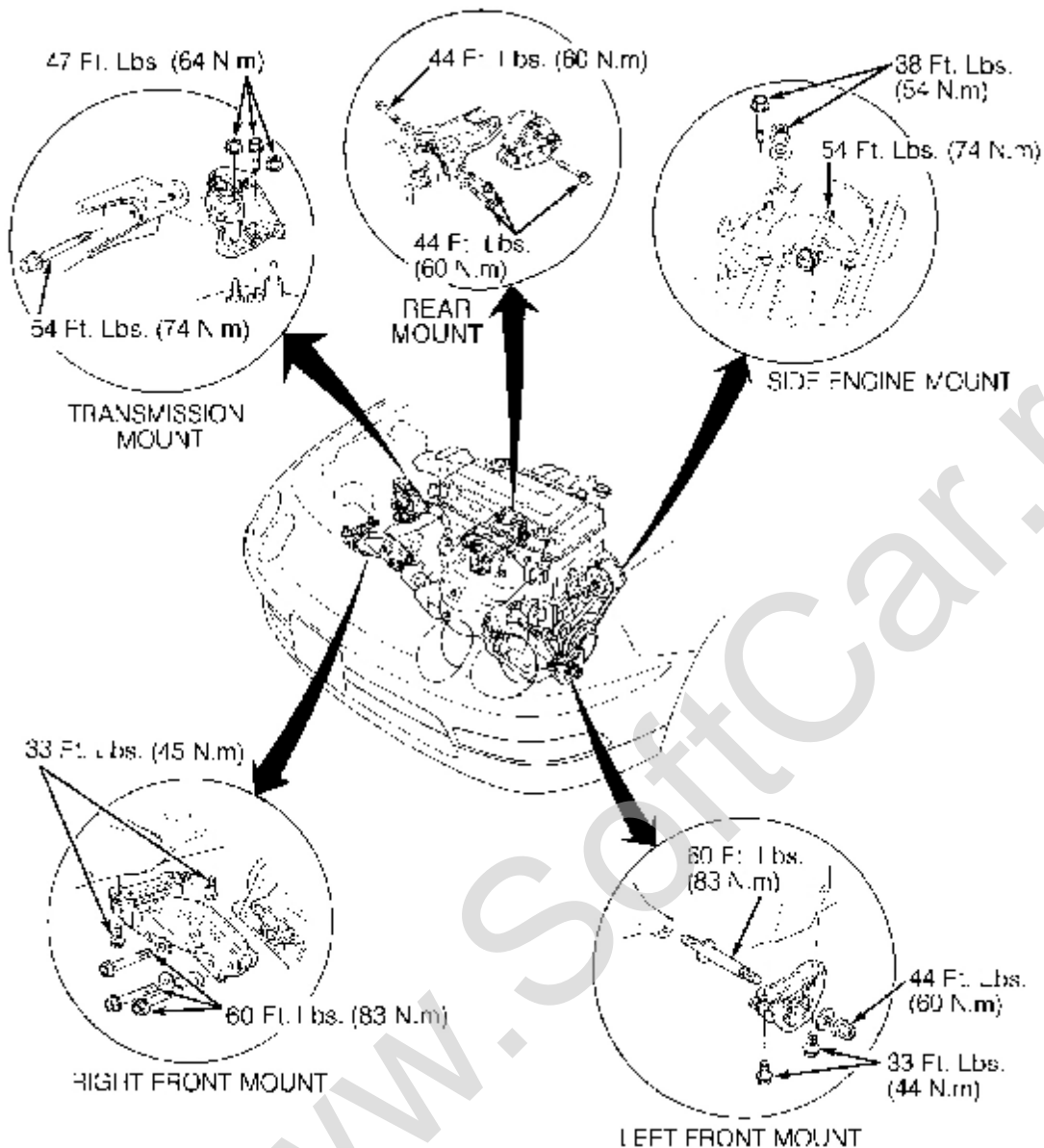

Fig. 5: Engine/Transaxle Mount Tightening Sequence
 Courtesy of AMERICAN HONDA MOTOR CO., INC.

INTAKE MANIFOLD

Removal

1. Disconnect negative battery cable. Release fuel pressure. See **FUEL PRESSURE RELEASE** . Carefully remove radiator cap to release cooling system pressure. Drain cooling system. Remove upper and lower radiator hoses. Remove air intake duct and air cleaner assembly.
2. Disconnect fuel inlet and return lines. Mark and disconnect vacuum hoses and wiring harness connectors. Remove EVAP canister hose from throttle body.
3. Remove brake booster and PCV hoses from intake manifold. Disconnect throttle cable. Remove

1999 Acura Integra LS

1999-2000 ENGINES 1.8L VTEC 4-Cylinder

coolant by-pass hoses. Remove intake manifold nuts, intake manifold, and gasket.

Installation

Clean gasket surfaces. Install intake manifold, using NEW intake manifold gasket. Tighten intake manifold nuts to specification, using a crisscross pattern in 2-3 stages, beginning with inner nuts. See **TORQUE SPECIFICATIONS** . To complete installation, reverse removal procedure. Refill and bleed air from cooling system. See **BLEEDING COOLING SYSTEM** .

EXHAUST MANIFOLD**Removal**

Disconnect negative battery cable. Remove oil dipstick. Remove exhaust manifold heat shield. Disconnect exhaust pipe from exhaust manifold. Remove exhaust manifold bracket. Disconnect oxygen sensor wiring. Remove exhaust manifold bolts. Remove exhaust manifold and gasket.

Installation

To install, reverse removal procedure. Tighten bolts to specification. See **TORQUE SPECIFICATIONS** .

CYLINDER HEAD**Removal**

1. Allow engine to cool to less than 100°F (38°C). Disconnect negative battery cable. Drain cooling system. Release fuel pressure. See **FUEL PRESSURE RELEASE** . Mark and disconnect all hoses. Remove strut brace. Rotate crankshaft pulley counterclockwise until No. 1 piston is at TDC of compression stroke and timing marks are aligned. See **Fig. 6** .
2. Remove intake air duct. Remove EVAP canister hose. Remove water by-pass and PCV hoses. Remove brake booster vacuum and fuel return hoses. Remove throttle cable from throttle body.
3. Remove/disconnect engine wiring harness connectors and harness clamps from cylinder head and intake manifold. Remove spark plug wires and distributor. Remove upper radiator hose and heater hose. Disconnect engine ground cable at valve cover.
4. Remove power steering pump with hoses attached, and wire aside. Remove heat shield. Remove A/C compressor belt and generator belt. Remove cruise control actuator. Remove side engine mount. Remove valve cover. Remove timing belt. See **TIMING BELT** .
5. Remove camshaft sprockets and back cover. Remove exhaust manifold and intake manifold. Loosen valve adjuster screws. Remove camshaft retainer plates, camshaft retainers and camshafts. In reverse order of tightening sequence, loosen cylinder head bolts 1/3 turn at a time until all are loose. See **Fig. 7** . Remove cylinder head.

Inspection

1. Ensure all mating surfaces are clean. Measure cylinder block surface for warpage. Ensure cylinder block warpage does not exceed 0.003" (0.08 mm).
2. Measure cylinder head warpage. Resurface cylinder head if warpage is greater than 0.002" (0.05 mm). Maximum resurface limit is 0.002" (0.05 mm).
3. Ensure cylinder head dowel pins, oil control jet, and "O" ring are installed in block. See **Fig. 8** .

Installation

1. Ensure No. 1 piston is at TDC of compression stroke. Apply a light coat of engine oil to cylinder head bolt threads and bottom of bolt head. Install cylinder head using NEW gasket and tighten cylinder head bolts to specification in 2 stages and in sequence. See **Fig. 7**.
2. Install intake manifold onto cylinder head with NEW gasket and tighten nuts to specification in a crisscross pattern, beginning with inner nuts. Install exhaust manifold with NEW gasket and NEW nuts. Tighten nuts to specification in a crisscross pattern, beginning with inner nuts. See **TORQUE SPECIFICATIONS**.
3. Install camshafts. See **CAMSHAFTS**. Install camshaft sprockets. Install timing belt. See **TIMING BELT**. To complete installation, reverse removal procedure. Tighten remaining bolts/nuts to specification. See **TORQUE SPECIFICATIONS**.

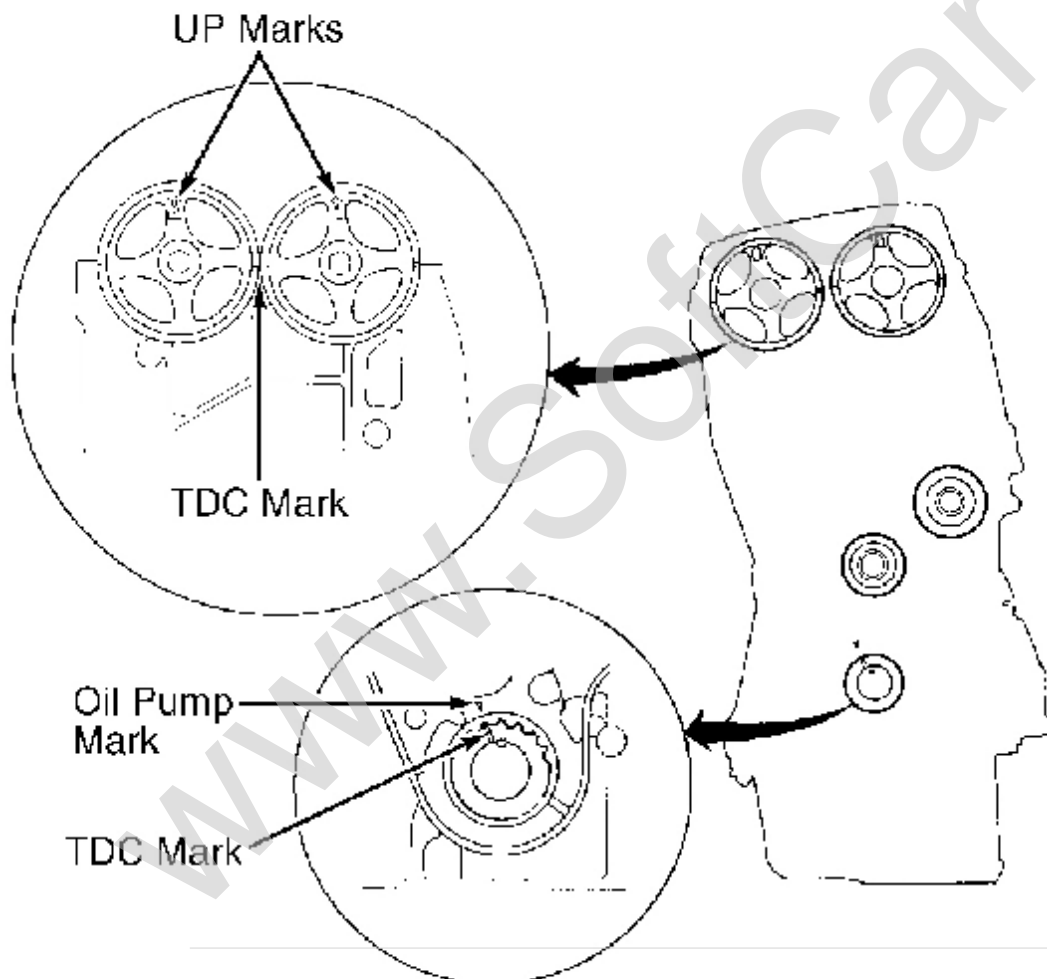

G97E08442

Fig. 6: Aligning Timing Marks

Courtesy of AMERICAN HONDA MOTOR CO., INC.

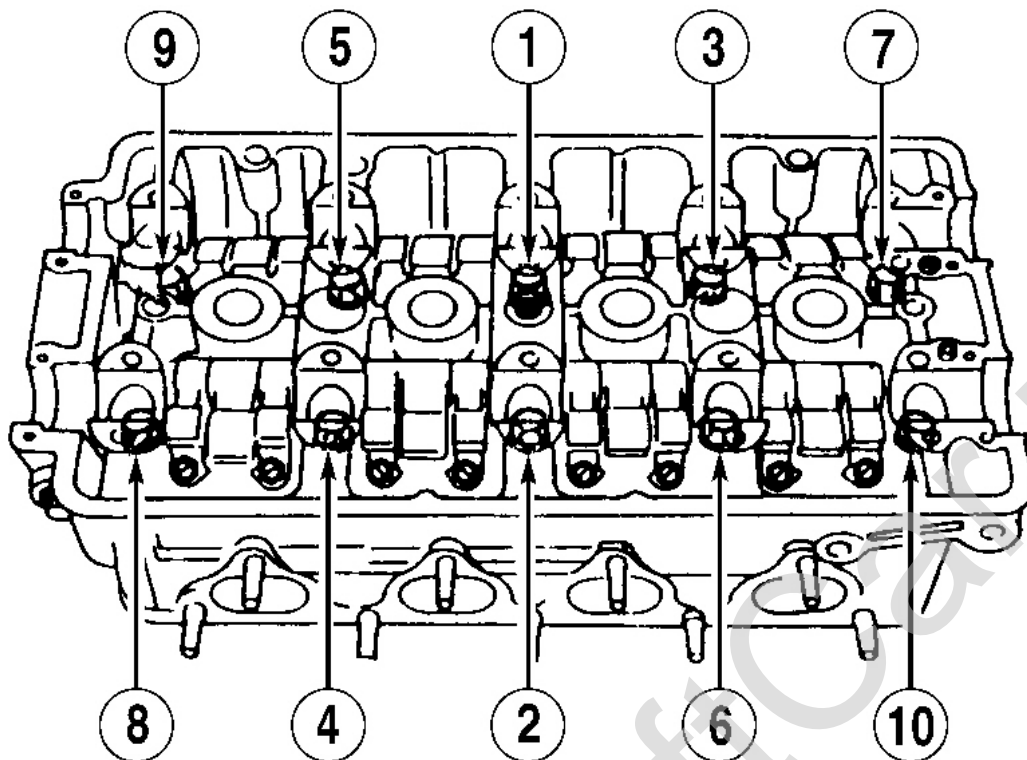

G93F00104

Fig. 7: Cylinder Head Tightening Sequence
Courtesy of AMERICAN HONDA MOTOR CO., INC.

1999 Acura Integra LS

1999-2000 ENGINES 1.8L VTEC 4-Cylinder

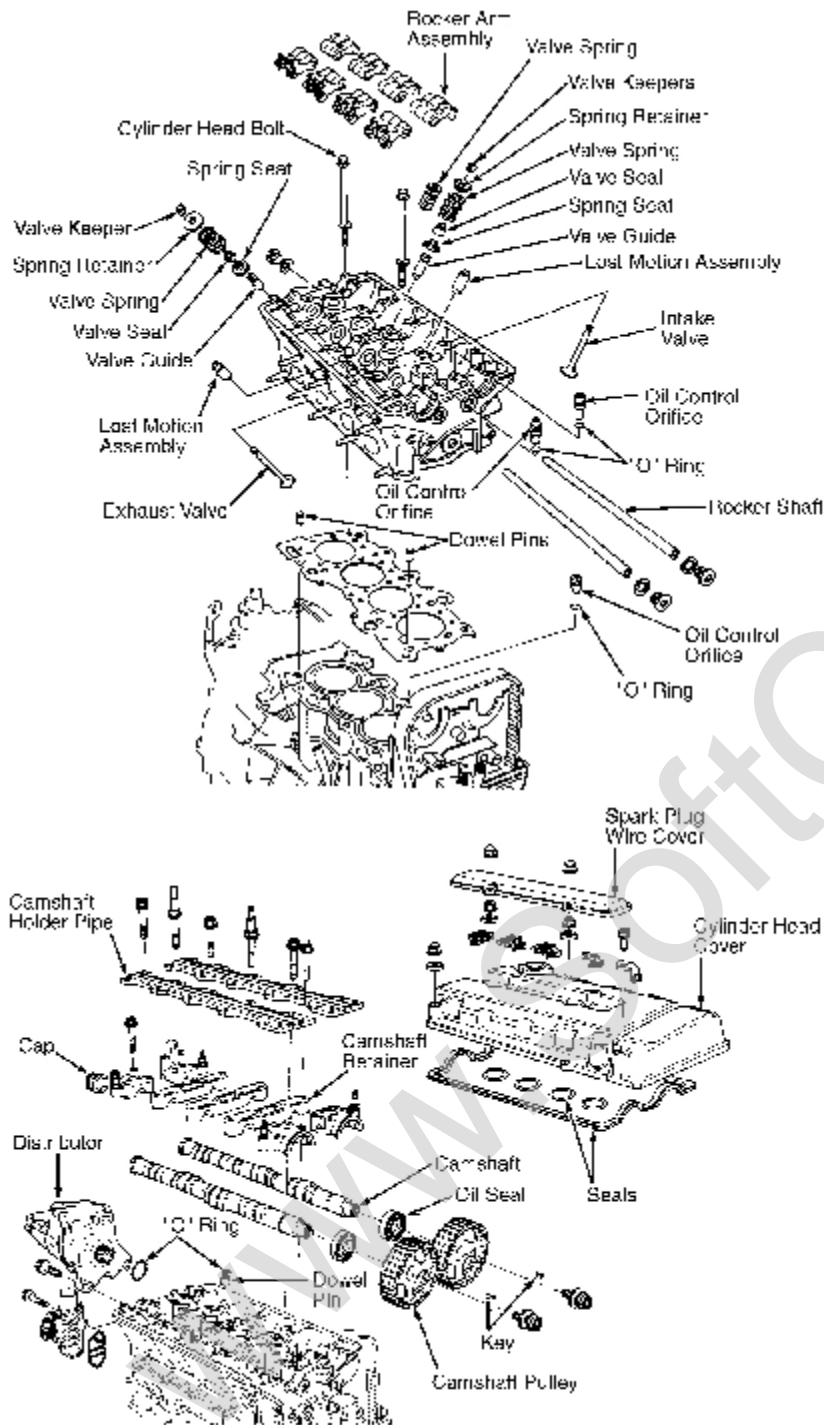

Fig. 8: Exploded View Of Cylinder Head, Camshaft & Rocker Arm Assemblies
 Courtesy of AMERICAN HONDA MOTOR CO., INC.

CRANKSHAFT FRONT OIL SEAL

Removal

Remove timing belt. See **TIMING BELT** . Remove crankshaft timing belt sprocket. Remove front

1999 Acura Integra LS

1999-2000 ENGINES 1.8L VTEC 4-Cylinder

crankshaft oil seal.

Installation

Lubricate crankshaft and oil seal lip with grease. Install oil seal using Seal Driver (07LAD-PR4010A) until seal driver bottoms against oil pump. To complete installation, reverse removal procedure.

TIMING BELT

Removal

1. Ensure No. 1 piston is at TDC of compression stroke. Mark timing belt with an arrow indicating direction of rotation. Raise and support vehicle. Remove left front wheel and wheelwell splash shield. Remove power steering pump belt, A/C belt and generator belt. Remove cruise control actuator. Remove side engine mount.
2. Remove valve cover. Remove crankshaft pulley bolt and pulley. Remove middle and lower timing belt covers. See **Fig. 9** . Loosen timing belt adjuster bolt 180 degrees. Push on timing belt tensioner to release tension from belt, then retighten adjuster bolt. Remove timing belt. See **Fig. 9** .

Installation

1. Ensure No. 1 piston is at TDC of compression stroke. Install timing belt onto sprockets. **DO NOT** bend or twist belt excessively. Ensure arrow on belt points in direction of rotation. Adjust timing belt tension. See **TIMING BELT TENSION** under ADJUSTMENTS.
2. To complete installation, reverse removal procedure. Lubricate threads only of crankshaft pulley bolt, leaving underside of bolt head dry. Tighten crankshaft pulley bolt to 147 ft. lbs. (200 N.m), loosen, then retighten to 133 ft. lbs. (180 N.m). Tighten remaining bolts/nuts to specification. See **TORQUE SPECIFICATIONS** .

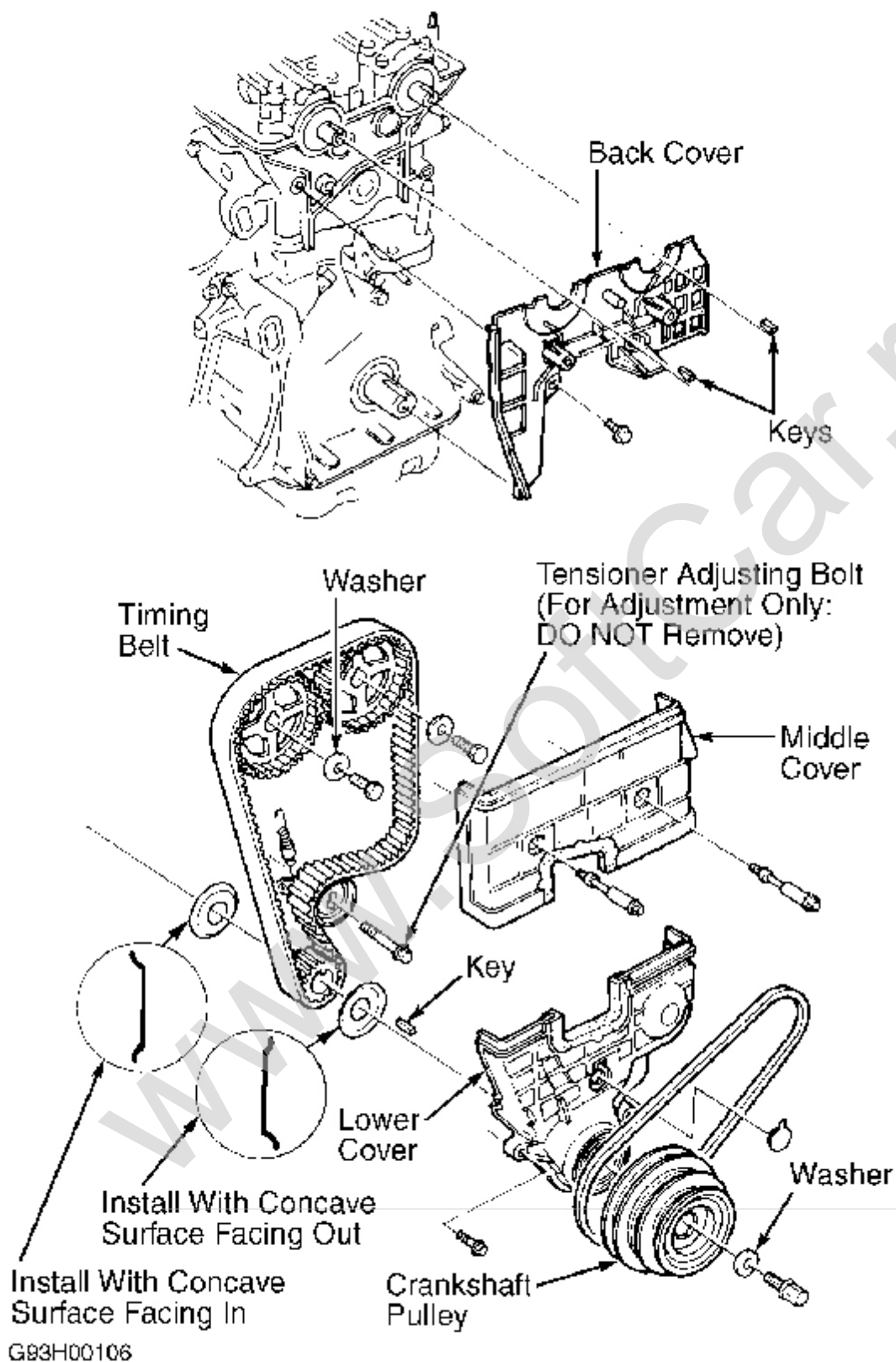

Fig. 9: Exploded View Of Timing Belt Components

1999 Acura Integra LS

1999-2000 ENGINES 1.8L VTEC 4-Cylinder

Courtesy of AMERICAN HONDA MOTOR CO., INC.

CAMSHAFTS

Removal

1. Disconnect negative battery cable. Remove valve cover and middle timing belt cover. See **Fig. 9** . Rotate crankshaft counterclockwise to bring No. 1 piston to TDC of its compression stroke, with UP marks on camshaft sprockets pointing up. See **Fig. 6** .
2. Remove distributor. Loosen timing belt adjuster bolt 180 degrees. Push tensioner to release tension from belt. Retighten adjuster bolt. Remove timing belt. Remove camshaft sprockets. Mark camshaft retainers and rocker arms for installation reference. Loosen valve adjuster screws and camshaft retainer bolts. Remove camshafts and rocker arms.

Installation

1. Lubricate camshaft journals and bearings. Install rocker arms (if removed) into original positions. Install camshafts with keyways facing up. Install camshaft oil seals. Apply sealant to mating surfaces of camshaft retainers at each end. Ensure arrows on camshaft retainers point toward timing belt. Ensure rockers do not bind on valves.
2. Lightly tighten camshaft retainer bolts and ensure rocker arms are positioned on valve stems properly. Tighten camshaft bolts to specification in sequence. See **Fig. 10** . See **TORQUE SPECIFICATIONS** . To complete installation, reverse removal procedure. Tighten remaining bolts/nuts to specification. See **TORQUE SPECIFICATIONS** . Adjust timing belt tension and valve clearance. See **TIMING BELT TENSION** and **VALVE CLEARANCE** under ADJUSTMENTS.

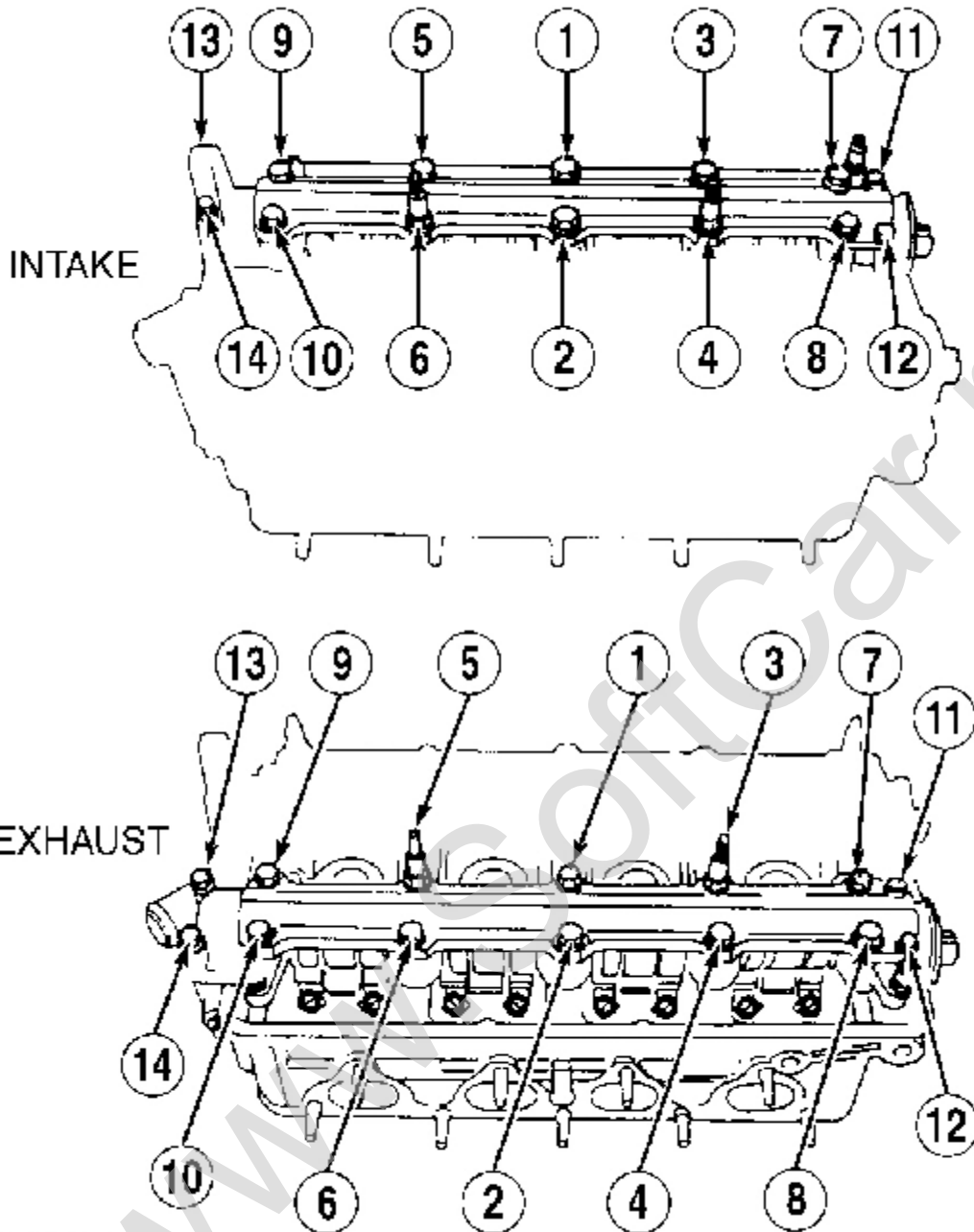

G93I00107

Fig. 10: Tightening Camshaft Bolts

Courtesy of AMERICAN HONDA MOTOR CO., INC.

REAR CRANKSHAFT OIL SEAL

Removal

1. Disconnect negative battery cable. Remove transaxle assembly. See appropriate article in CLUTCHES (M/T) or TRANSMISSION SERVICING (A/T).

1999 Acura Integra LS

1999-2000 ENGINES 1.8L VTEC 4-Cylinder

2. On manual transmission models, place reference marks on clutch pressure plate and flywheel for installation reference. Remove pressure plate and clutch disc. Remove flywheel. Remove seal.

NOTE: When installing **NEW** crankshaft oil seal, align hole in Driver Attachment (07948-SB00101) with pin on crankshaft.

Installation

Apply a light coat of engine oil to crankshaft and lip of new seal. Using Seal Driver (07749-0010000) and Driver Attachment (07948-SB00101), install **NEW** seal. To complete installation, reverse removal procedure.

WATER PUMP

Removal

Remove timing belt. See **TIMING BELT** . Remove camshaft sprockets and timing belt back cover. See **Fig. 9** . See **CAMSHAFTS** . Remove 5 retaining bolts, water pump, and "O" ring.

Installation

1. Clean gasket surfaces. Install water pump. Install **NEW** "O" ring. To complete installation, reverse removal procedure. Tighten bolts to specifications. See **TORQUE SPECIFICATIONS** .
2. Adjust timing belt tension. See **TIMING BELT TENSION** under ADJUSTMENTS. Fill and bleed air from cooling system. See **BLEEDING COOLING SYSTEM** in SPECIFICATIONS article in ENGINE COOLING.

OIL PAN

Removal

1. Drain engine oil. Rotate crankshaft counterclockwise to align crankshaft pulley timing mark with pointer on lower timing belt cover. Remove valve cover and middle timing belt cover. See **Fig. 9** . Remove accessory drive belts.
2. Remove crankshaft pulley and lower timing belt cover. Remove timing belt and crankshaft sprocket. See **TIMING BELT** . Remove oil pan bolts and nuts. Remove oil pan.

Installation

Clean gasket mating surfaces. Install oil pan. Tighten bolts/nuts to specification. See **TORQUE SPECIFICATIONS** . To complete installation, reverse removal procedure.

OVERHAUL

CYLINDER HEAD

NOTE: Identify valves and valve springs as they are removed so that each item can be reinstalled in its original position.

1999 Acura Integra LS

1999-2000 ENGINES 1.8L VTEC 4-Cylinder

Cylinder Head

Ensure all mating surfaces are clean. Measure cylinder head warpage. If warpage is greater than 0.002" (0.05 mm), resurface cylinder head. Maximum resurface limit is 0.002" (0.05 mm).

Valve Springs

Measure free length of valve springs. If measurements are not within specification, replace valve springs. See **VALVES & VALVE SPRINGS** table under ENGINE SPECIFICATIONS.

Valve Stem Oil Seals

Intake and exhaust valve stem seals are not interchangeable. Intake valve stem seals have a White spring around neck of seal. Oil seals for exhaust valves have a Black spring around neck of seal. Use Valve Stem Seal Installer (KD-2899) to install valve stem seals.

Valve Guide Inspection

Measure valve guide clearance using a dial indicator placed on edge of valve head. With valve .4" (10 mm) off seat, rock valve stem from side to side. Replace valve guides if stem-to-guide clearance is not within specification. See **CYLINDER HEAD** table under ENGINE SPECIFICATIONS.

Valve Guide Removal

CAUTION: DO NOT heat cylinder head using a torch, or heat cylinder head to greater than 300°F (150°C). Excessive heat may loosen valve seats.

1. Use a hot plate or oven to heat cylinder head to 300°F (150°C). Use Valve Guide Driver (07742-0010100), or fabricate valve guide remover from an air-impact chisel. See **Fig. 11** . Using an air hammer and valve guide remover, drive valve guide 0.079" (2.0 mm) toward combustion chamber.
2. Turn head over. Working from combustion chamber side of head, drive valve guide out toward camshaft side of head. If valve guide does not move, drill valve guide with a 5/16" drill bit and try again to drive out guide.

CAUTION: Drill guides in extreme cases only. Cylinder head damage can occur if valve guide breaks.

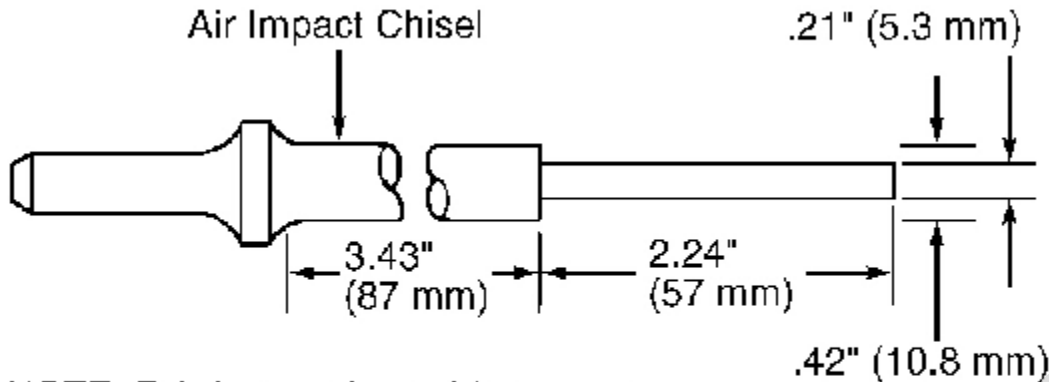

NOTE: Fabricate valve guide remover to dimensions shown.

G92H00065

Fig. 11: Fabricating Valve Guide Remover

Courtesy of AMERICAN HONDA MOTOR CO., INC.

Valve Guide Installation

1. Cool new valve guides in freezer for about one hour. Remove new valve guides from freezer as needed. Install valve guides using .22" (5.5 mm) Valve Guide Driver (07742-0010100).
2. Install new valve guides from camshaft side of cylinder head. Apply thin coat of oil to valve guide and drive each guide into heated cylinder head until driver bottoms on head. If replacing all valve guides, reheat cylinder head as necessary.
3. Valve guide installed height must be 0.494-0.514" (12.55-13.05 mm). Using cutting oil, ream new valve guides by rotating Valve Guide Reamer (07HAH-PJ7010B) clockwise the full length of valve guide bore. Measure valve stem-to-guide clearance. See **CYLINDER HEAD** table under ENGINE SPECIFICATIONS.

NOTE: Always reface valve seat after replacing valve guide.

Valve Seat

Valve seat replacement procedure is not available from manufacturer.

Valve Seat Correction Angles

If valve guides are to be replaced, perform guide replacement before refacing valve seats. If seat width is too wide, use 60-degree stone to raise seat, or 30-degree stone to lower seat. Ensure valve seat width is within specification. See **CYLINDER HEAD** table under ENGINE SPECIFICATIONS.

Valve Stem Installed Height

After servicing valves, measure valve stem installed height. See **Fig. 12** . If valve stem installed height exceeds specification, replace valve. See **CYLINDER HEAD** table under ENGINE SPECIFICATIONS. If

valve stem installed height still exceeds limit, replace cylinder head.

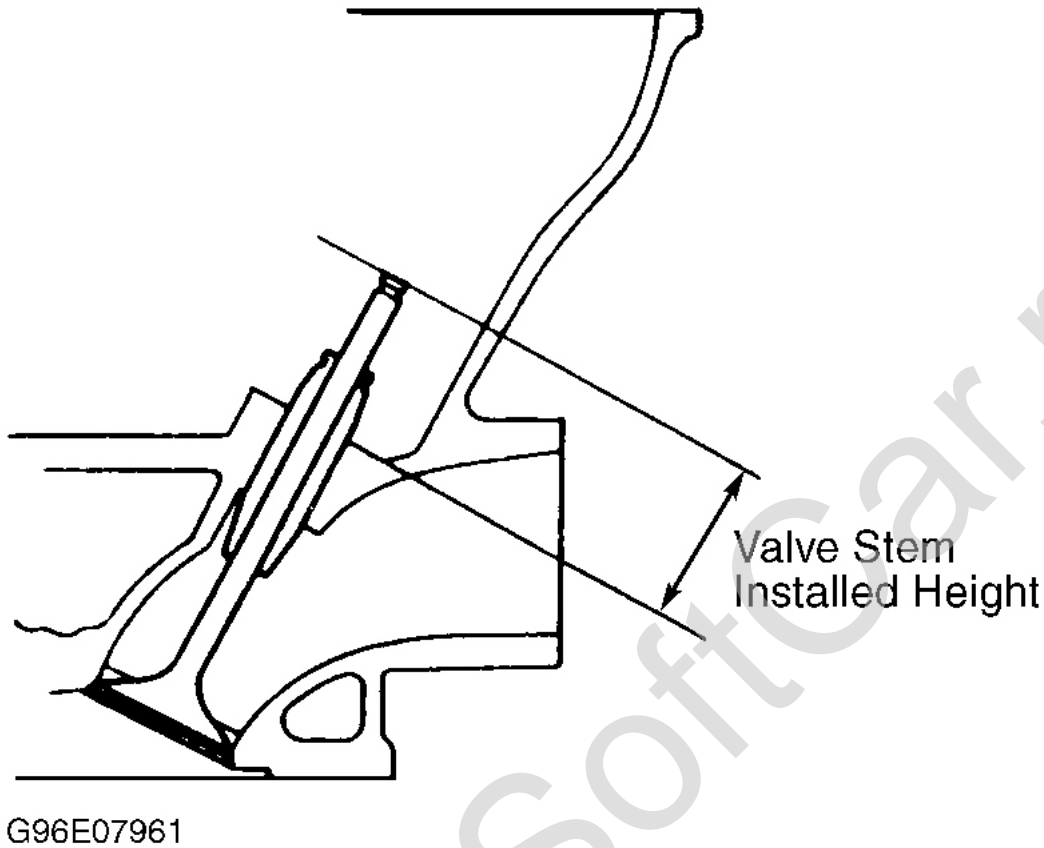

Fig. 12: Measuring Valve Stem Installed Height
Courtesy of AMERICAN HONDA MOTOR CO., INC.

VALVE TRAIN

Removal

Place a rubber band around each set of rocker arms to keep them together. Remove intake and exhaust rocker shaft oil control orifices. Remove VTEC solenoid valve and sealing bolts. Screw a 12-mm bolt into end of rocker shaft. Pull bolt head to remove rocker shaft and rocker arms. Mark parts for installation reference as they are removed.

NOTE: Shape of intake oil orifices are different than exhaust oil orifices. Ensure reinstallation in original locations.

Inspection

1. Push rocker arm pistons manually. If they do not move smoothly, replace rocker arm assembly. Remove lost motion assembly from cylinder head and test by pushing plunger with finger. If lost

1999 Acura Integra LS

1999-2000 ENGINES 1.8L VTEC 4-Cylinder

motion assembly does not move smoothly, replace assembly.

2. Measure diameter of intake and exhaust rocker shafts at first rocker location. Measure ID of rocker arms, and check for out of round condition. Repeat for all rocker arms. If out of round condition is detected, replace rocker arms. Always replace rocker arms as a set of 3.

Installation

Lubricate all components before installation. Install all components into original locations. Back off valve adjuster screws before installation. If holes in cylinder head and rocker shafts are not in line, turn shaft with 12-mm bolt threaded into end. To complete installation, reverse removal procedure.

CYLINDER BLOCK ASSEMBLY

Piston & Rod Assembly

1. Each rod is sorted into 1 of 4 size tolerance ranges. Size depends on crank journal bore. Number from 21 to 26 is stamped on side of rod big end and rod cap. Any combination of numbers from 21 to 26 may be found on any engine.

NOTE: Reference numbers are for big end bore codes and do not indicate rod position in engine.

2. Nominal connecting rod big end bore size is 1.89" (48.0 mm). Install piston and connecting rod so arrow on top of piston points toward timing belt, and numbers marked on connecting rod face timing belt.

NOTE: All replacement piston pins are oversize.

Piston Pin Removal

1. Assemble Piston Pin Tools. Insert Base Spring (07973-6570600) and Base Insert (07GAF-PH60300) into Base (07973-6570500) and attach Base Head (07HAF-PL20102). Adjust Pin Driver Shaft (07973-PE00310) so driver length is 2.035" (51.69 mm). Install Driver Head (07973-PE00320) and Pilot Collar (07LAF-PR30100). Place piston onto Base, and using a Hydraulic Press, remove piston pin. See **Fig. 13**.
2. When removing or installing piston pin, set piston in press with embossed side facing up. Align lugs on base insert with recessed part of piston.

1 ASSEMBLE PISTON PIN SET AS SHOWN

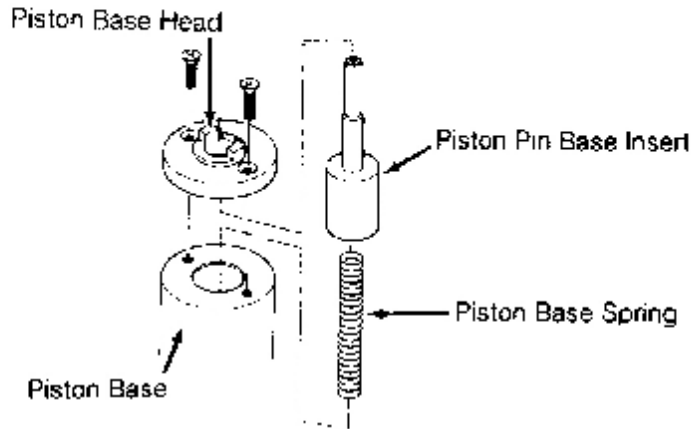

2. ADJUST LENGTH "A" OF PISTON PIN DRIVER
"A": 2.035" (51.70 mm)

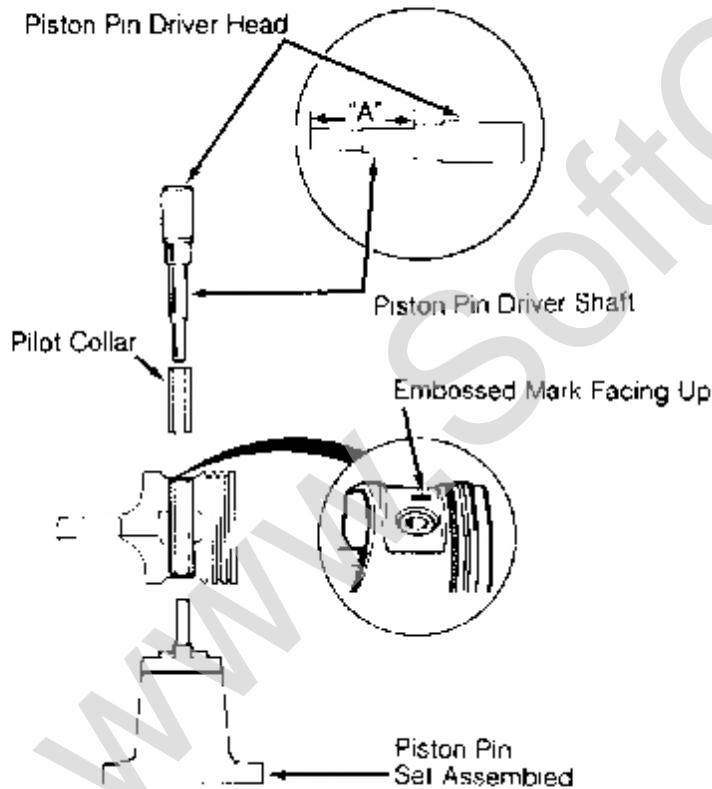

93E00111

Fig. 13: Removing Piston Pin

Courtesy of AMERICAN HONDA MOTOR CO., INC.

Piston Pin Inspection

1. Measure diameter of piston pin. Zero dial indicator to piston pin diameter. Insert dial indicator into piston pin bore to measure piston pin-to-piston clearance. If clearance exceeds specification, install oversize piston pin and recheck clearance. See **PISTONS, PINS & RINGS** table under ENGINE

1999 Acura Integra LS

1999-2000 ENGINES 1.8L VTEC 4-Cylinder

SPECIFICATIONS.

2. Measure difference between piston pin diameter and connecting rod small end diameter. Ensure interference fit between piston and connecting rod is within specification. See **PISTONS, PINS & RINGS** table under ENGINE SPECIFICATIONS.

Piston Pin Installation

1. Ensure piston and connecting rod are positioned so arrow on top of piston is pointing toward timing belt and numbers marked on connecting rod face timing belt. Turn handle on Piston Pin Driver (07973-PE00320) so piston driver length is 2.035" (51.69 mm).
2. Install Pilot Collar (07LAF-PR30100) into piston and connecting rod. Lightly oil new piston pin. Place piston onto Base. Press in piston pin.

Fitting Pistons

1. Using a feeler gauge, ensure piston-to-cylinder bore clearance is within specification. See **PISTONS, PINS & RINGS** table under ENGINE SPECIFICATIONS. If piston clearance exceeds service limit, re-bore cylinder and install oversize piston.
2. Measure piston diameter at a point 0.6" (15 mm) from bottom of piston skirt. If diameter is not within specification, replace piston. See **PISTONS, PINS & RINGS** table under ENGINE SPECIFICATIONS.

Piston Rings

1. Using inverted piston, push NEW piston ring into cylinder bore 0.6-0.8" (15-20 mm) from bottom. Measure piston ring end gap. Repeat for each ring. See **PISTONS, PINS & RINGS** table under ENGINE SPECIFICATIONS.
2. Clean piston ring grooves thoroughly. Install piston rings with identification mark facing up. Using a feeler gauge, measure piston ring side clearance between ring and ring land.
3. If ring lands are excessively worn, replace piston. See **PISTONS, PINS & RINGS** table under ENGINE SPECIFICATIONS. Align piston ring end gaps properly on piston. See **Fig. 14**.

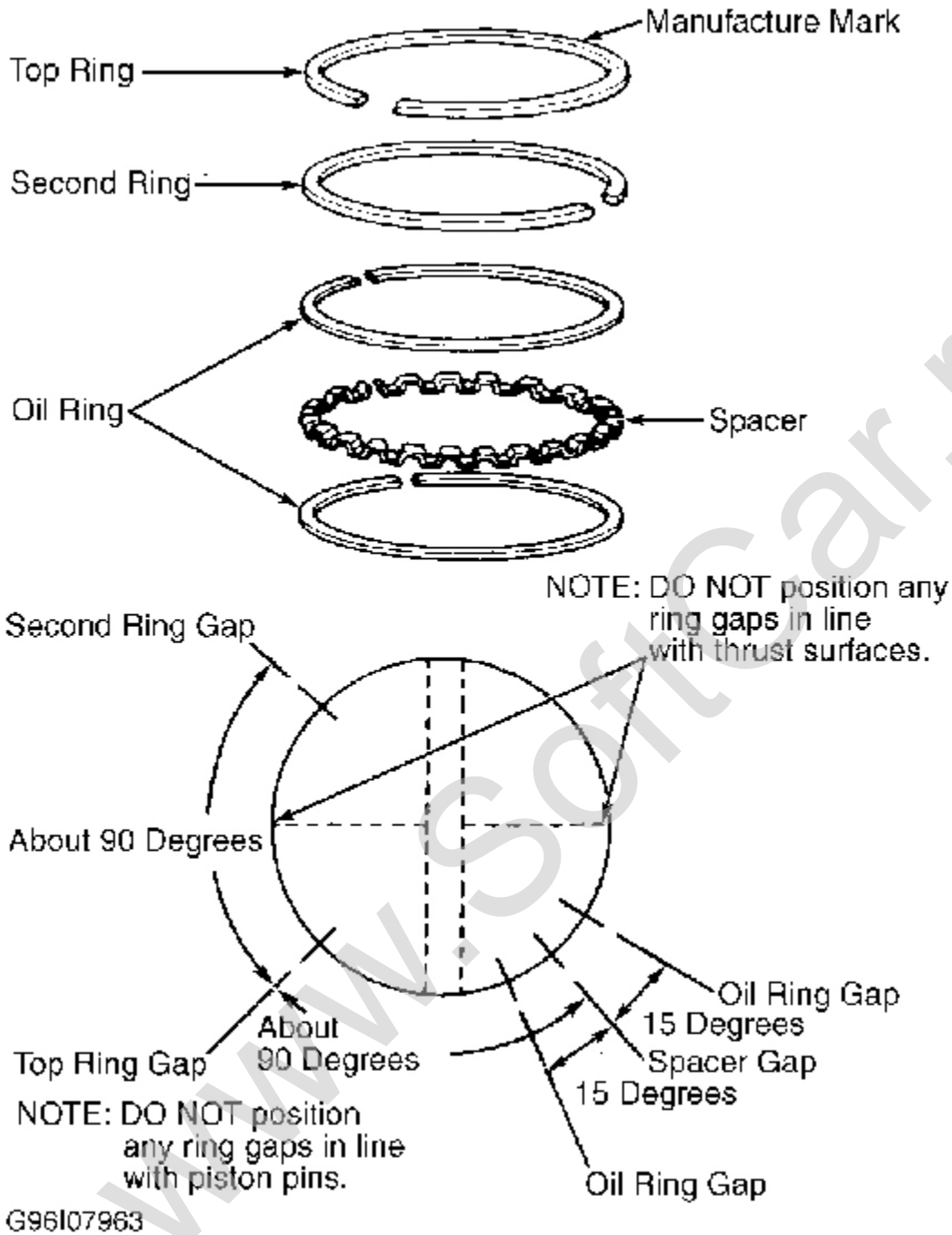

Fig. 14: Installing Piston Rings

Courtesy of AMERICAN HONDA MOTOR CO., INC.

NOTE: A number indicating connecting rod bore is stamped on side of each connecting rod and cap. Connecting rod journal diameter codes (letters) are stamped on crankshaft counterweight pads. See Fig. 15 . Use both codes when ordering replacement bearings.

1999 Acura Integra LS

1999-2000 ENGINES 1.8L VTEC 4-Cylinder

Rod Bearings

1. Using Plastigage, measure rod bearing oil clearance. On B18C1 engine, tighten bearing cap to 33 ft. lbs. (44 N.m). On B18C5 engine, use connecting rod gauge. Install nuts finger tight. Install connecting rod gauge. Tighten nuts until connecting rod gauge reads .005-.006" (0.13-0.15 mm). See **CRANKSHAFT, MAIN & CONNECTING ROD BEARINGS** table under ENGINE SPECIFICATIONS.
2. If oil clearance is not within specification, install a new bearing set (same color code) and recheck oil clearance. DO NOT shim or file cap to adjust oil clearance.
3. If oil clearance is still incorrect, try next larger or smaller bearing. Measure oil clearance once more. If proper oil clearance cannot be obtained by using larger or smaller bearings, replace crankshaft and repeat procedure.

www.SoftCar.ru

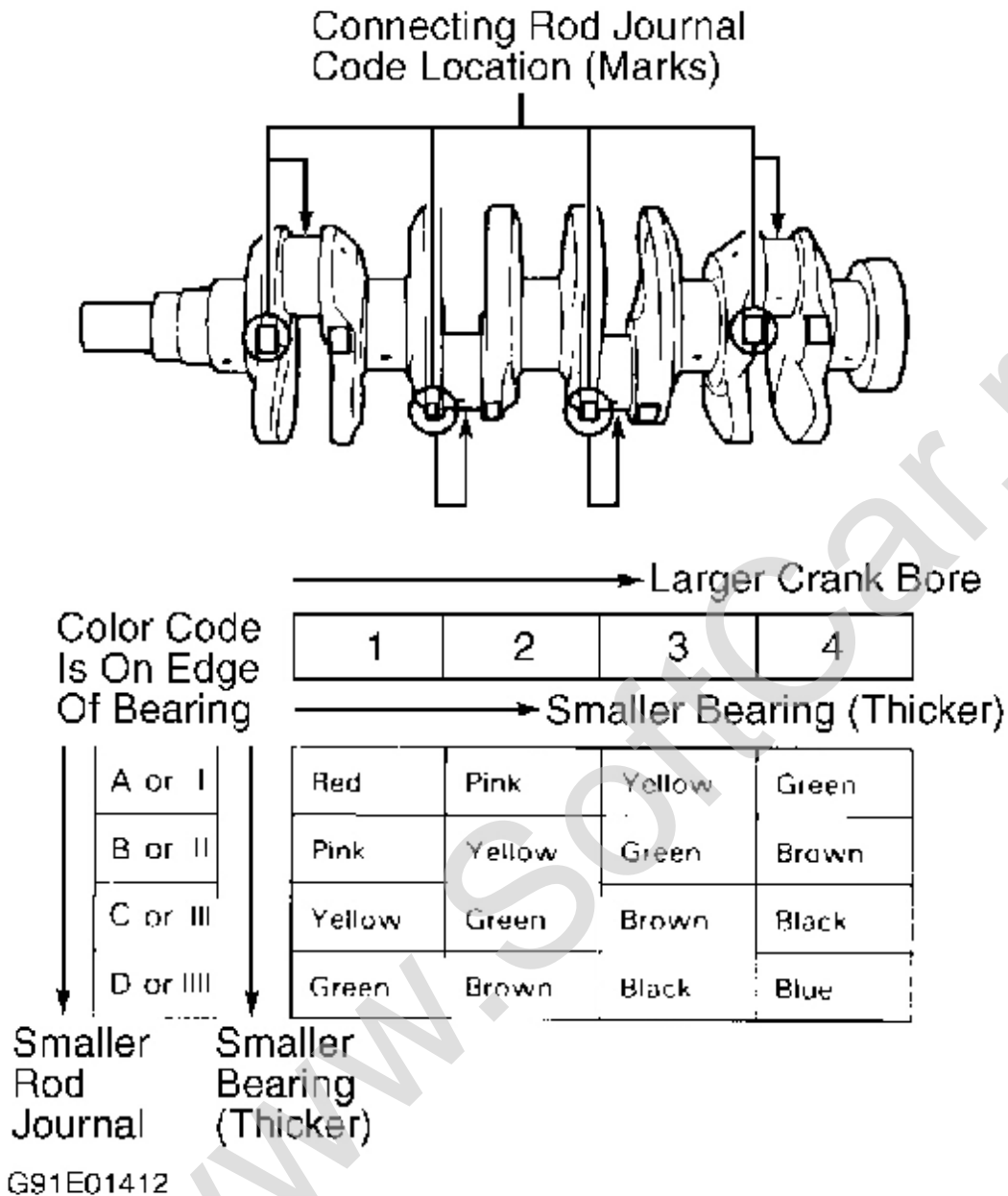

Fig. 15: Connecting Rod Journal & Bearing Identification Codes
Courtesy of AMERICAN HONDA MOTOR CO., INC.

NOTE: A letter indicating main journal bore diameters is stamped on cylinder block. See Fig. 16 . Use these codes, together with crankshaft main journal diameter numbers, when ordering replacement bearings.

Crankshaft & Main Bearings

1. Remove oil pan, oil screen, oil pump, and baffle plate. Rotate crankshaft so No. 2 and 3 crankpins are at bottom of stroke. Remove rear crankshaft oil seal cover. Remove main bearing cap bolts, in

1999 Acura Integra LS

1999-2000 ENGINES 1.8L VTEC 4-Cylinder

sequence and 1/3 turn at a time until all bolts are loosened.

2. Remove cap bridge. Mark all main bearing caps for assembly reference. Remove main bearing caps and bearing halves. Remove rod bearing caps. Lift crankshaft from block. DO NOT damage journals.
3. Using a lathe or "V" blocks to support crankshaft, measure crankshaft runout, out-of-round, and taper. If any measurement exceeds service limit, replace crankshaft. See **CRANKSHAFT, MAIN & CONNECTING ROD BEARINGS** table under ENGINE SPECIFICATIONS.
4. Install crankshaft into block. Measure oil clearance with Plastigage. Tighten main bearing caps No. 1 and 5 to 56 ft. lbs. (76 N.m). Tighten main bearing caps No. 2, 3 and 4 to 49 ft. lbs. (67 N.m). Remove main bearing caps and measure Plastigage.
5. If oil clearance is not within specification, install a new bearing set (same color code) and recheck oil clearance. If oil clearance is still incorrect, try next larger or smaller bearing and measure oil clearance once more. If proper oil clearance cannot be obtained by using larger or smaller bearings, replace crankshaft and repeat procedure.

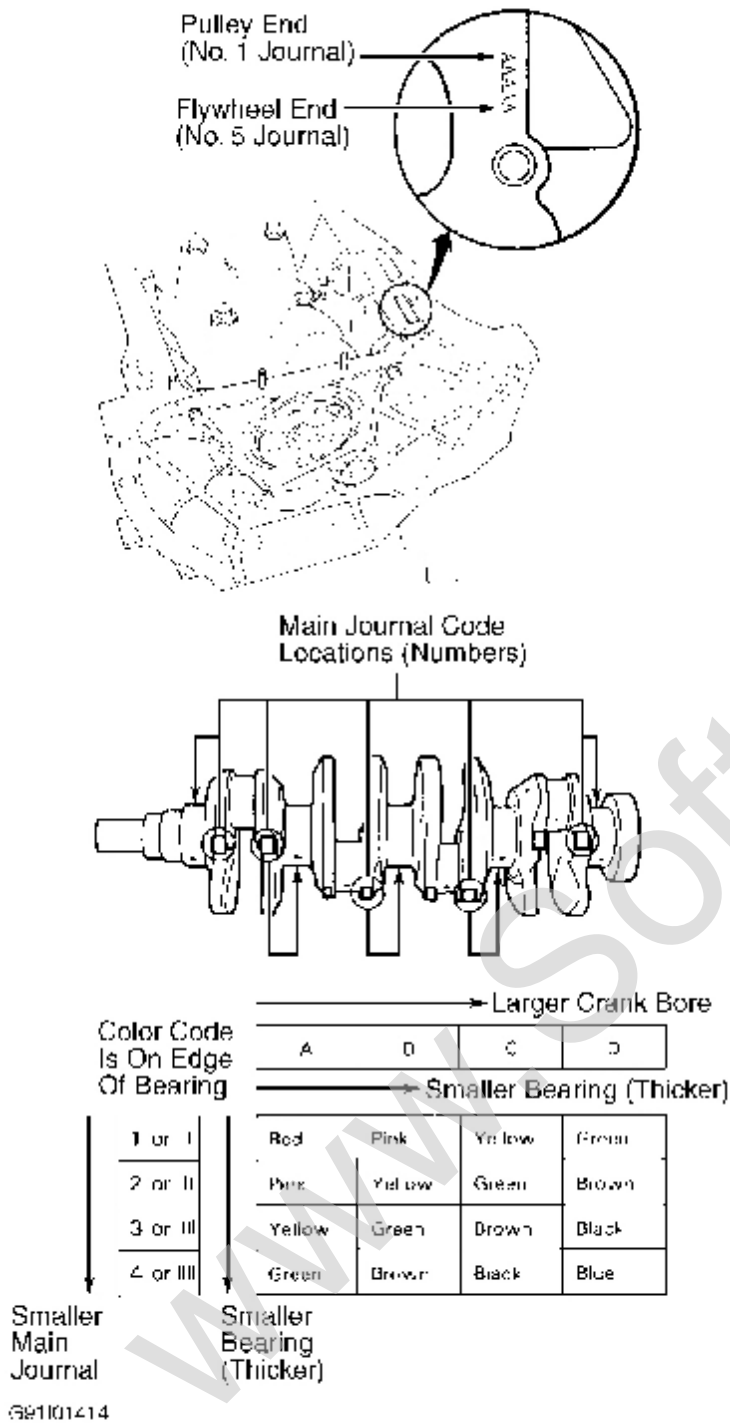

Fig. 16: Crankshaft Main Journal & Bearing Identification Codes
 Courtesy of AMERICAN HONDA MOTOR CO., INC.

Thrust Bearing

1. Measure crankshaft end play with a dial indicator. If end play exceeds specification, inspect thrust washers and thrust surface of crankshaft. See **CRANKSHAFT, MAIN & CONNECTING ROD BEARINGS** table under ENGINE SPECIFICATIONS.

1999 Acura Integra LS

1999-2000 ENGINES 1.8L VTEC 4-Cylinder

2. Replace worn parts as necessary. Thrust washer thickness is fixed. DO NOT change thrust washer thickness by grinding or shimming. Install thrust washers with grooved side out.

Cylinder Block

1. Measure cylinder bore out-of-round and taper. If either out-of-round or taper exceeds specification, re-bore cylinder for oversize pistons. If any cylinder exceeds oversize bore service limit, replace cylinder block. See [CYLINDER BLOCK](#) table under ENGINE SPECIFICATIONS.
2. Using a feeler gauge and straightedge, measure cylinder block deck surface for warpage. Service limit is 0.003" (0.08 mm). If cylinder bore is okay, hone cylinder to obtain a 60-degree crosshatch pattern. After honing, wash cylinder bore with hot soapy water. Air-dry cylinder bore, and apply engine oil to prevent rusting.

ENGINE OILING**ENGINE LUBRICATION SYSTEM**

A rotor-type oil pump draws oil from oil pan and delivers it under pressure to main and connecting rod bearings. Oil jets at bottom of block spray oil upward to lubricate piston and cylinder wall. An oil passage carries oil to camshaft and rocker arms. Oil spray lubricates valve stems.

Crankcase Capacity

Crankcase capacity is 4.2 qts. (4.0L) including oil filter. Oil capacity is 5.1 qts. (4.8L) after engine overhaul.

Oil Pressure

Oil pressure at idle should be 10 psi (0.7 kg/cm²) minimum. Oil pressure at 3000 RPM should be 50 psi (3.5 kg/cm²) minimum.

OIL PUMP**Removal & Disassembly**

Remove oil pan. See [OIL PAN](#) under REMOVAL & INSTALLATION. Remove oil screen and oil pump assembly. Remove screws from oil pump housing. Separate housing and cover.

Inspection

Measure radial clearance between inner and outer rotors. Measure axial clearance between housing and outer rotor. Inspect both rotors and pump housing for scoring or other damage. Replace components if clearance measurements are not within specification. See [OIL PUMP SPECIFICATIONS](#) table.

OIL PUMP SPECIFICATIONS

Application	In. (mm)
Inner Rotor-To-Outer Rotor	
Radial Clearance	
Standard (New)	0.002-0.006 (0.05-0.15)
Service Limit	0.008 (0.20)

1999 Acura Integra LS

1999-2000 ENGINES 1.8L VTEC 4-Cylinder

Housing-To-Outer Rotor	
Axial Clearance	
Standard (New)	0.001-0.003 (0.02-0.08)
Service Limit	0.006 (0.15)
Radial Clearance	
Standard (New)	0.004-0.007 (0.10-0.18)
Service Limit	0.008 (0.20)

Reassembly & Installation

1. Reassemble oil pump, using Loctite on pump housing screws. Ensure oil pump turns freely. Install dowel pins and NEW "O" ring into cylinder block. Clean oil pump mating surfaces. Apply Liquid Sealant (08718-0001) to cylinder block mating surface of oil pump.
2. Apply sealant to threads of inner bolt holes. Install oil screen and oil pump before sealant dries. Wait at least 30 minutes before filling crankcase with oil. To complete installation, reverse removal procedure.

TORQUE SPECIFICATIONS**TORQUE SPECIFICATIONS**

Application	Ft. Lbs. (N.m)
A/C Compressor Bracket Bolts	32 (44)
A/C Compressor Mounting Bolts	17 (23)
Camshaft Retaining Bolts	(1)
Camshaft Sprocket Bolts	41 (56)
Connecting Rod Nuts	
B18C1 Engine	(2) 32 (44)
B18C5 Engine	(3)
Crankshaft Pulley Bolt	133 (180)
Cylinder Head Bolts	(4) 63 (85)
Distributor Mount Bolts	17 (23)
Engine Block-To-Transaxle Housing Bolts	47 (64)
Engine Mount Bolts	(5)
Exhaust Manifold Nuts	23 (31)
Exhaust Pipe Flange Nuts	40 (54)
Flexplate (A/T)	(6) 55 (75)
Flywheel Bolts (M/T)	(6) 76 (103)
Fuel Filter Banjo Bolt	24 (33)
Generator Belt Adjustment Bolt	18 (24)
Generator Mount Bolt	32 (44)
Intake Manifold Nuts	17 (23)
Main Bearing Cap Bolts	(7)
Oil Pump Bolts	

1999 Acura Integra LS

1999-2000 ENGINES 1.8L VTEC 4-Cylinder

6-mm Bolts	(8)
8-mm Bolts	17 (23)
Power Steering Mount Bolt	17 (23)
Rocker Arm Lock Nuts	14 (19)
Rocker Arm Shaft Sealing Bolt	47 (64)
Shift Lever Torque Rod Bolt	16 (22)
Timing Belt Tension Adjuster Bolt	40 (54)
INCH Lbs. (N.m)	
Crankshaft Baffle Plate	97 (11)
Crankshaft Rear Seal Cover Bolts	97 (11)
Oil Pan Bolts	⁽⁶⁾ 106 (12)
Oil Pump Screen Nuts	97 (11)
Timing Belt Cover Bolts	88 (10)
Valve Cover Nuts	88 (10)
Water Pump Bolt	106 (12)

- (1) Tighten 6-mm bolts to 88 INCH lbs. (10 N.m). Tighten 8-mm bolts to 20 ft. lbs. (27 N.m). Bolts must be tightened in sequence shown. See **Fig. 10** .
- (2) Tighten connecting rod nuts in 2 stages. First tighten nuts to 15 ft. lbs. (20 N.m), then to 32 ft. lbs. (44 N.m).
- (3) See **CYLINDER BLOCK ASSEMBLY** under OVERHAUL.
- (4) Tighten cylinder head bolts in 2 stages. First tighten bolts to 22 ft. lbs. (30 N.m), and then to 63 ft. lbs. (85 N.m). See **Fig. 7** .
- (5) See **Fig. 5** .
- (6) Tighten in a crisscross pattern.
- (7) Tighten main bearing bolts in 2 stages. First tighten bolts to 22 ft. lbs. (30 N.m), then tighten bearing caps No. 1 and 5 to 54 ft. lbs. (73 N.m) and bearing caps No. 2, 3 and 4 to 47 ft. lbs. (64 N.m).
- (8) Tighten to 97 INCH lbs. (11 N.m).

ENGINE SPECIFICATIONS

GENERAL SPECIFICATIONS

Application	Specification
Displacement	110 Cu. In. (1.8L)
Bore	3.19" (81 mm)
Stroke	3.43 In. (87.2 mm)
Compression Ratio	
B18C1 Engine	10:1
B18C5 Engine	10:1
Fuel System	SFI

CRANKSHAFT, MAIN & CONNECTING ROD BEARINGS

www.SoftCar.ru	
18 февраля 2007 г. 19:12:14	Page 30 © 2005 Mitchell Repair Information Company, LLC.

1999 Acura Integra LS

1999-2000 ENGINES 1.8L VTEC 4-Cylinder

Application	In. (mm)
Crankshaft	
End Play	
Standard	0.004-0.014 (0.10-0.35)
Service Limit	0.018 (0.45)
Runout	
Standard	0.001 (0.03)
Service Limit	0.002 (0.05)
Main Bearings	
Journal Diameter	
Except No. 3	2.1644-2.1654 (54.976-55.001)
No. 3	2.1643-2.1653 (54.973-54.998)
Journal Out-Of-Round	
Standard	0.0002 (0.005)
Service Limit	0.0004 (0.010)
Journal Taper	
Standard	0.0002 (0.005)
Service Limit	0.0004 (0.010)
Oil Clearance	
Except No. 3 Journal	
Standard	0.0009-0.0017 (0.023-0.043)
Service Limit	0.0020 (0.050)
No. 3 Journal	
Standard	0.0012-0.0019 (0.030-0.048)
Service Limit	0.0024 (0.060)
Connecting Rod Bearings	
Journal Diameter	
	1.7707-1.7717 (44.976-45.001)
Journal Out-Of-Round	
Standard	0.0002 (0.005)
Service Limit	0.0004 (0.010)
Journal Taper	
Standard	0.0002 (0.005)
Service Limit	0.0004 (0.010)
Oil Clearance	
Standard	0.0013-0.0020 (0.033-0.050)
Service Limit	0.0024 (0.060)

CONNECTING RODS

Application	In. (mm)
Bore Diameter	
Crankpin Bore	1.89 (48.0)
Pin Bore	0.8254-0.8267 (20.965-20.998)
End Play	
Standard	0.006-0.012 (0.15-0.30)

1999 Acura Integra LS

1999-2000 ENGINES 1.8L VTEC 4-Cylinder

Service Limit

0.016 (0.40)

PISTONS, PINS & RINGS

Application	In. (mm)
Pistons	
Clearance	
Standard	0.0004-0.0016 (0.010-0.040)
Service Limit	0.002 (0.050)
Diameter ⁽¹⁾	
Standard	3.1882-3.1886 (80.980-80.990)
Service Limit	3.1878 (80.970)
Oversize 0.010 (0.25)	3.1984-3.1988 (81.239-81.249)
Pins	
Diameter	0.8265-0.8268 (20.993-21.000)
Piston Fit	0.0004-0.0009 (0.010-0.022)
Rod Fit	0.0007-0.0014 (0.017-0.035)
Rings	
No. 1	
End Gap	0.008-0.014 (0.20-0.35)
Service Limit	0.024 (0.60)
Side Clearance	0.0018-0.0028 (0.045-0.071)
Service Limit	0.005 (0.13)
No. 2	
End Gap	0.016-0.022 (0.40-0.55)
Service Limit	0.028 (0.71)
Side Clearance	0.0016-0.0026 (0.040-0.066)
Service Limit	0.005 (0.13)
No. 3 (Oil)	
End Gap	0.008-0.020 (0.20-0.50)
Service Limit	0.028 (0.71)
(1) Measure at 0.6" (15 mm) from bottom of skirt.	

CYLINDER BLOCK

Application	In. (mm)
Cylinder Bore	
Standard Diameter	3.189-3.190 (81.00-81.02)
Service Limit	3.192 (81.07)
Maximum Taper	0.002 (0.05)
Maximum Re-bore Limit	0.010 (0.25)
Deck Warpage	
Maximum	0.002 (0.05)
Service Limit	0.003 (0.08)

VALVES & VALVE SPRINGSwww.SoftCar.ru

18 февраля 2007 г. 19:12:14

Page 32

© 2005 Mitchell Repair Information Company, LLC.

1999 Acura Integra LS

1999-2000 ENGINES 1.8L VTEC 4-Cylinder

Application	Specification
Intake Valves	
Face Angle	45°
Head Diameter	1.295-1.303" (32.89-33.09 mm)
Margin	
B18C1 Engine	
Standard	0.041-0.053" (1.04-1.35 mm)
Minimum Margin	0.033" (0.84 mm)
B18C5 Engine	
Standard	0.024-0.035" (0.61-0.89 mm)
Minimum Margin	0.016" (0.40 mm)
Stem Diameter	
Standard	0.2156-0.2159" (5.476-5.484 mm)
Service Limit	0.2144" (5.445 mm)
Exhaust Valves	
Face Angle	45°
Head Diameter	1.098-1.106" (27.89-28.09 mm)
Margin	
Standard	0.065-0.077" (1.65-1.95 mm)
Minimum Margin	0.057" (1.45 mm)
Stem Diameter	
Standard	0.2146-0.2150" (5.450-5.461 mm)
Service Limit	0.2134" (5.420 mm)
Valve Springs Free Length	
Intake (B18C1 Engine)	
Outer	1.616" (41.05 mm)
Inner	
NH ⁽¹⁾	1.424" (36.17 mm)
CH ⁽²⁾	1.425" (36.19 mm)
Intake (B18C5 Engine)	
Outer	1.700" (43.18 mm)
Inner	1.450" (36.83 mm)
Exhaust (B18C1 Engine)	
NH ⁽¹⁾	1.652" (41.96 mm)
CH ⁽²⁾	1.651" (41.94 mm)
Exhaust (B18C5 Engine)	
Outer	1.616" (41.04 mm)
Inner	1.424" (36.17 mm)
(1) NIHON HATSUJO manufactured valve spring.	
(2) CHUO HATSUJO manufactured valve spring.	

CYLINDER HEAD

www.SoftCar.ru	
18 февраля 2007 г. 19:12:14	Page 33 © 2005 Mitchell Repair Information Company, LLC.

1999 Acura Integra LS

1999-2000 ENGINES 1.8L VTEC 4-Cylinder

Application	Specification
Cylinder Head	
Height	5.589-5.593" (141.96-142.06 mm)
Maximum Warp	(1) 0.002" (0.05 mm)
Valve Seats	
Intake & Exhaust	
Seat Angle	45°
Seat Width (B18C1 Engine)	
Standard	0.049-0.061" (1.24-1.55 mm)
Service Limit	0.080" (2.03 mm)
Seat Width (B18C5 Engine)	
Standard	0.033-0.045" (0.84-1.14 mm)
Service Limit	0.080" (2.03 mm)
Valve Guides	
Intake & Exhaust	
Valve Guide I.D.	
Standard	0.217-0.218" (5.51-5.53 mm)
Service Limit	0.219" (5.56 mm)
Valve Guide Installed Height	
Standard	0.494-0.514" (12.54-13.05 mm)
Valve Stem-To-Guide Clearance	
Intake	
Standard	0.0010-0.0022" (0.025-0.055 mm)
Service Limit	0.003" (0.08 mm)
Exhaust	
Standard	0.0020-0.0031" (0.050-0.080 mm)
Service Limit	0.004" (0.10 mm)
(1) Maximum resurface limit is 0.008" (0.20 mm).	

CAMSHAFT

Application	In. (mm)
End Play	
Standard	0.002-0.006 (0.05-0.15)
Service Limit	0.02 (0.50)
Journal Runout	
Service Limit	0.001 (0.03)
Oil Clearance	
Standard	0.002-0.0035 (0.050-0.089)
Service Limit	0.006 (0.15)
Cam Lobe Height (B18C1 Engine)	
Intake	
Primary	1.3154 (33.411)
Mid	1.4322 (36.377)
Secondary	1.3601 (34.546)

1999 Acura Integra LS

1999-2000 ENGINES 1.8L VTEC 4-Cylinder

Exhaust	
Primary	1.3036 (33.111)
Mid	1.4063 (35.720)
Secondary	1.3536 (34.381)
Cam Lobe Height (B18C5 Engine)	
Intake	
Primary	1.3027 (33.088)
Mid	1.4138 (35.910)
Secondary	1.3674 (34.732)
Exhaust	
Primary	1.2907 (32.783)
Mid	1.4304 (36.332)
Secondary	1.3658 (34.691)

VALVE STEM INSTALLED HEIGHT ⁽¹⁾

Application	In. (mm)
Intake	
Standard	1.4750-1.4935 (37.465-37.935)
Service Limit	1.5033 (38.184)
Exhaust	
Standard	1.4632-1.4817 (37.165-37.635)
Service Limit	1.4915 (37.884)
(1) Measure from base of valve guide to tip of valve stem.	